

HYDRAULIC MOTORS MM

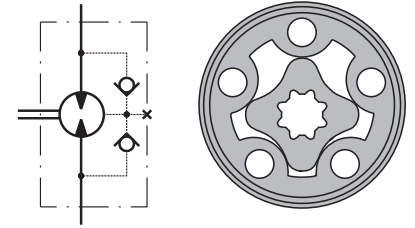

APPLICATION

- » Conveyors
- » Textile machines
- » Mining machinery
- » Machine tools
- » Ventilators
- » Construction plant equipment and access platforms etc.



CONTENTS

Specification data	5
Function diagrams	6÷8
Dimensions and mounting ...	9÷10
Shaft extensions	11
Permissible shaft loads	11
Order code	12

OPTIONS

- » Model - Spool valve, gerotor
- » With or without flange
- » Side and rear ports
- » Series with pressure valve(s)
- » Shafts - straight and splined
- » Metric and BSPP ports
- » Speed sensing;
- » Other special features

GENERAL

Max. Displacement, cm ³ /rev [in ³ /rev]	50 [3.05]
Max. Speed, [RPM]	2440
Max. Torque, daNm [in-lb]	cont.: 4,5 [398] int.: 5,8 [513]
Max. Output, kW [HP]	3,2 [4.3]
Max. Pressure Drop, bar [PSI]	cont.: 105 [1500] int.: 140 [2030]
Max. Oil Flow, lpm [GPM]	25 [6.6]
Min. Speed, [RPM]	20
Pressure fluid	Mineral based- HLP(DIN 51524) or HM(ISO 6743/4)
Temperature range, °C [°F]	-40÷140 [-40÷284]
Optimal Viscosity range, mm ² /s [SUS]	20÷75 [98÷347]
Filtration	ISO code 20/16 (Min. recommended fluid filtration of 25 microns)

MMP Series with Integrated Internal Crossover Relief Valve
A → B, Δp=100 or 50 bar [1450 or 725 PSI]

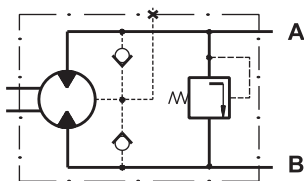

MMP Series with Integrated Internal Crossover Relief Valve
B → A, Δp=100 or 50 bar [1450 or 725 PSI]

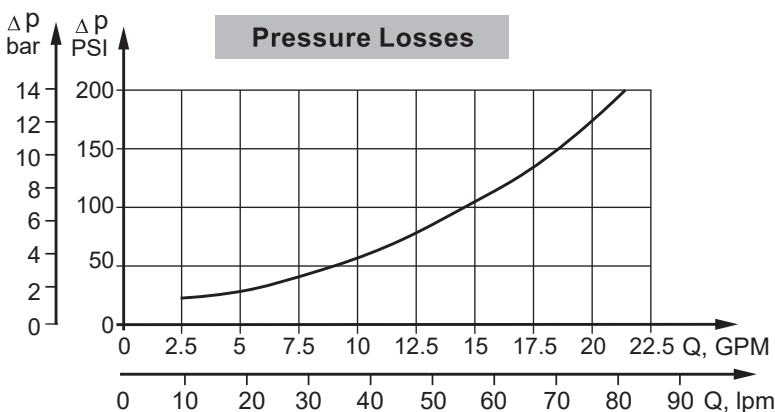
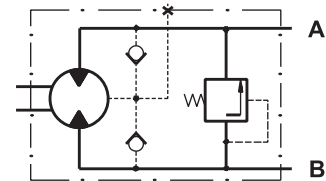

MMD Series with Integrated Internal Crossover Relief Valves
A ↔ B, Δp=100 or 50 bar [1450 or 725 PSI]

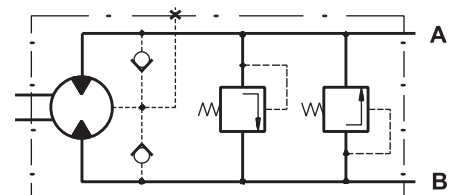

SPECIFICATION DATA

Type		MM 8	MM 12.5	MM 20	MM 32	MM 40	MM 50
Displacement, cm³/rev [in³/rev]		8,2 [5]	12,9 [79]	20 [1.22]	31,8 [1.93]	40 [2.44]	50 [3.05]
Max. Speed, [RPM]	Cont.	1950	1550	1000	630	500	400
	Int.*	2440	1940	1250	790	625	500
Max. Torque daNm [lb-in]	Cont.	1,1 [106]	1,6 [150]	2,5 [230]	4,0 [375]	4,1 [375]	4,5 [398]
	Int.*	1,5 [133]	2,3 [205]	3,5 [311]	5,7 [506]	5,7 [506]	5,8 [513]
	Peak**	2,1 [187]	3,3 [293]	5,1 [453]	6,4 [568]	6,6 [584]	8 [708]
Max. Output kW [HP]	Cont.	1,8 [2.4]	2,4 [3.3]	2,4 [3.3]	2,4 [3.3]	1,8 [2.5]	1,7 [2.48]
	Int.*	2,6 [3.6]	3,2 [4.3]	3,2 [4.3]	3,2 [4.3]	3,0 [4.0]	2,1 [2.8]
Max. Pressure Drop bar [PSI]	Cont.	105 [1500]	105 [1500]	105 [1500]	105 [1500]	82,5 [1200]	70 [1015]
	Int.*	140 [2030]	140 [2030]	140 [2030]	140 [2030]	110 [1600]	90 [1300]
	Peak**	200 [2900]	200 [2900]	200 [2900]	200 [2900]	140 [2000]	125 [1815]
Max. Oil Flow lpm [GPM]	Cont.	16 [4.2]	20 [5.5]	20 [5.5]	20 [5.5]	20 [5.5]	20 [5.5]
	Int.*	20 [5.5]	25 [6.6]	25 [6.6]	25 [6.6]	25 [6.6]	25 [6.6]
Max. Inlet Pressure bar [PSI]	Cont.	140 [2030]	140 [2030]	140 [2030]	140 [2030]	140 [2030]	140 [2030]
	Int.*	175 [2540]	175 [2540]	175 [2540]	175 [2540]	175 [2540]	175 [2540]
	Peak**	225 [3260]	225 [3260]	225 [3260]	225 [3260]	225 [3260]	225 [3260]
Max. Return Pressure without Drain Line or Max. Pressure in Drain Line, bar [PSI]	Cont. 0-100 RPM	140 [2030]	140 [2030]	140 [2030]	140 [2030]	140 [2030]	140 [2030]
	Cont. 100-400 RPM	105 [1500]	105 [1500]	105 [1500]	105 [1500]	105 [1500]	105 [1500]
	Cont. 400-800 RPM	50 [725]	50 [725]	50 [725]	50 [725]	50 [725]	50 [725]
	Cont. >800 RPM	20 [290]	20 [290]	20 [290]	-	-	-
Max. Return Pressure with Drain Line bar [PSI]	Int.* 0-max. RPM	140 [2030]	140 [2030]	140 [2030]	140 [2030]	140 [2030]	140 [2030]
	Cont.	140 [2030]	140 [2030]	140 [2030]	140 [2030]	140 [2030]	140 [2030]
	Int.*	175 [2540]	175 [2540]	175 [2540]	175 [2540]	175 [2540]	175 [2540]
	Peak**	225 [3260]	225 [3260]	225 [3260]	225 [3260]	225 [3260]	225 [3260]
Max. Starting Pressure with Unloaded Shaft, bar [PSI]		4 [60]	4 [60]	4 [60]	4 [60]	4 [60]	4 [60]
Min. Starting Torque daNm [lb-in]	At max. press. drop Cont.	0,7 [65]	105 [1,2]	2,1 [190]	3,4 [300]	3,3 [295]	3,7 [330]
	At max. press. drop Int.*	1,0 [90]	150 [1,7]	2,9 [260]	4,8 [425]	4,6 [400]	4,8 [425]
Min. Speed***, [RPM]		50	40	30	30	25	20
Weight, kg [lb] For "F" flange: + 0,200 [.441]	MM	1,9 [4.2]	2,0 [4.41]	2,1 [4.63]	2,2 [4.85]	2,3 [5.07]	2,5 [5.51]
	MMF(S)	2,0 [4.41]	2,1 [4.63]	2,2 [4.85]	2,3 [5.07]	2,4 [5.29]	2,6 [5.73]
	MMP	2,2 [4.85]	2,3 [5.07]	2,4 [5.29]	2,5 [5.51]	2,6 [5.73]	2,8 [6.17]
	MMD	2,6 [5.73]	2,7 [5.95]	2,8 [6.17]	2,9 [6.39]	3,0 [6.61]	3,2 [7.05]

* Intermittent operation: the permissible values may occur for max. 10% of every minute.

** Peak load: the permissible values may occur for max. 1% of every minute.

*** For speeds lower than given, consult factory or your regional manager.

- Intermittent speed and intermittent pressure must not occur simultaneously.
- Recommended filtration is per ISO cleanliness code 20/16. A nominal filtration of 25 micron or better.
- Recommend using a premium quality, anti-wear type mineral based hydraulic oil HLP(DIN51524) or HM (ISO 6743/4).
If using synthetic fluids consult the factory for alternative seal materials.
- Recommended minimum oil viscosity 13 mm²/s [70 SUS] at 50°C [122°F].
- Recommended maximum system operating temperature is 82°C [180°F].
- To assure optimum motor life fill with fluid prior to loading and run at moderate load and speed for 10-15 minutes.

FUNCTION DIAGRAMS

MM 8

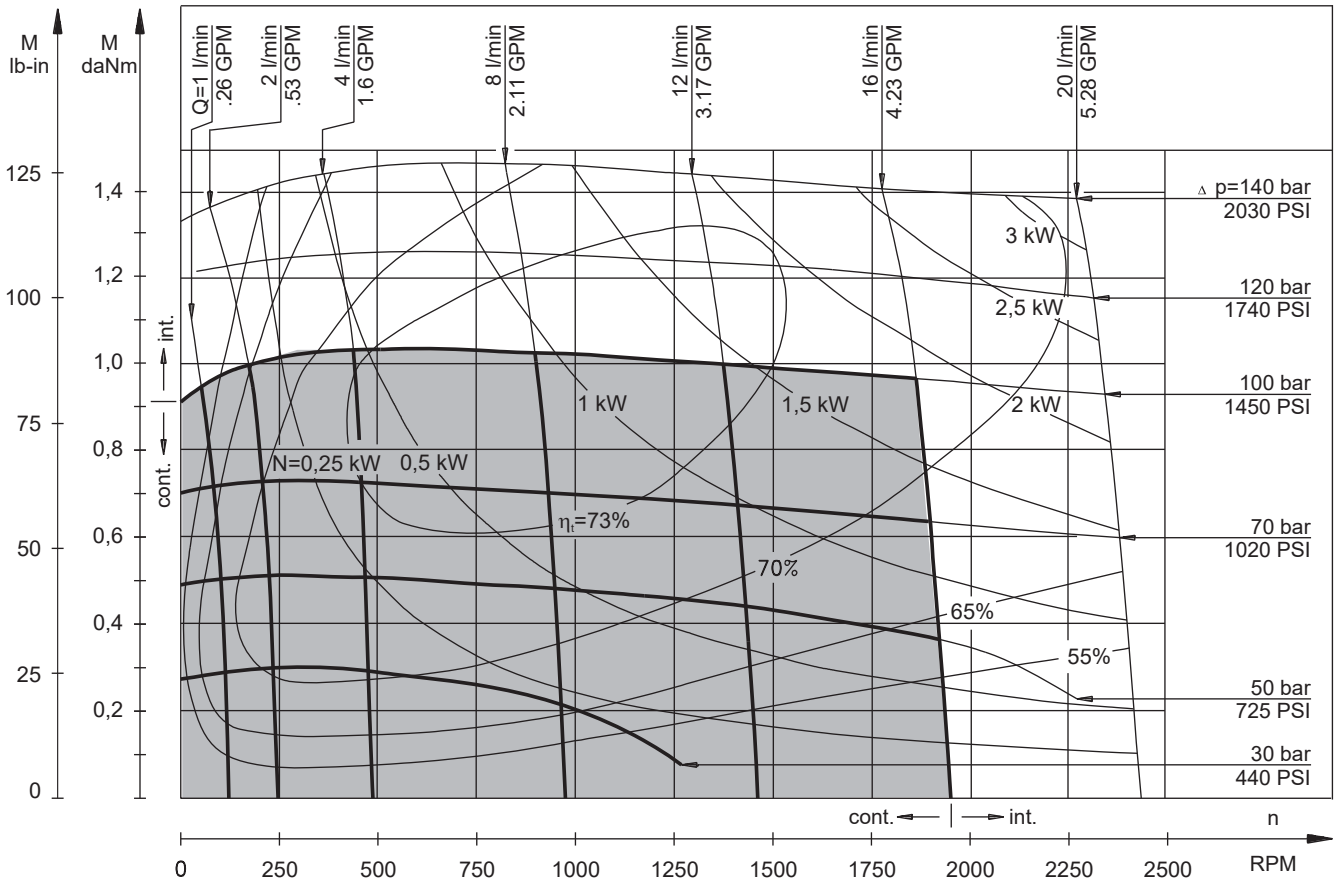

MM 12,5

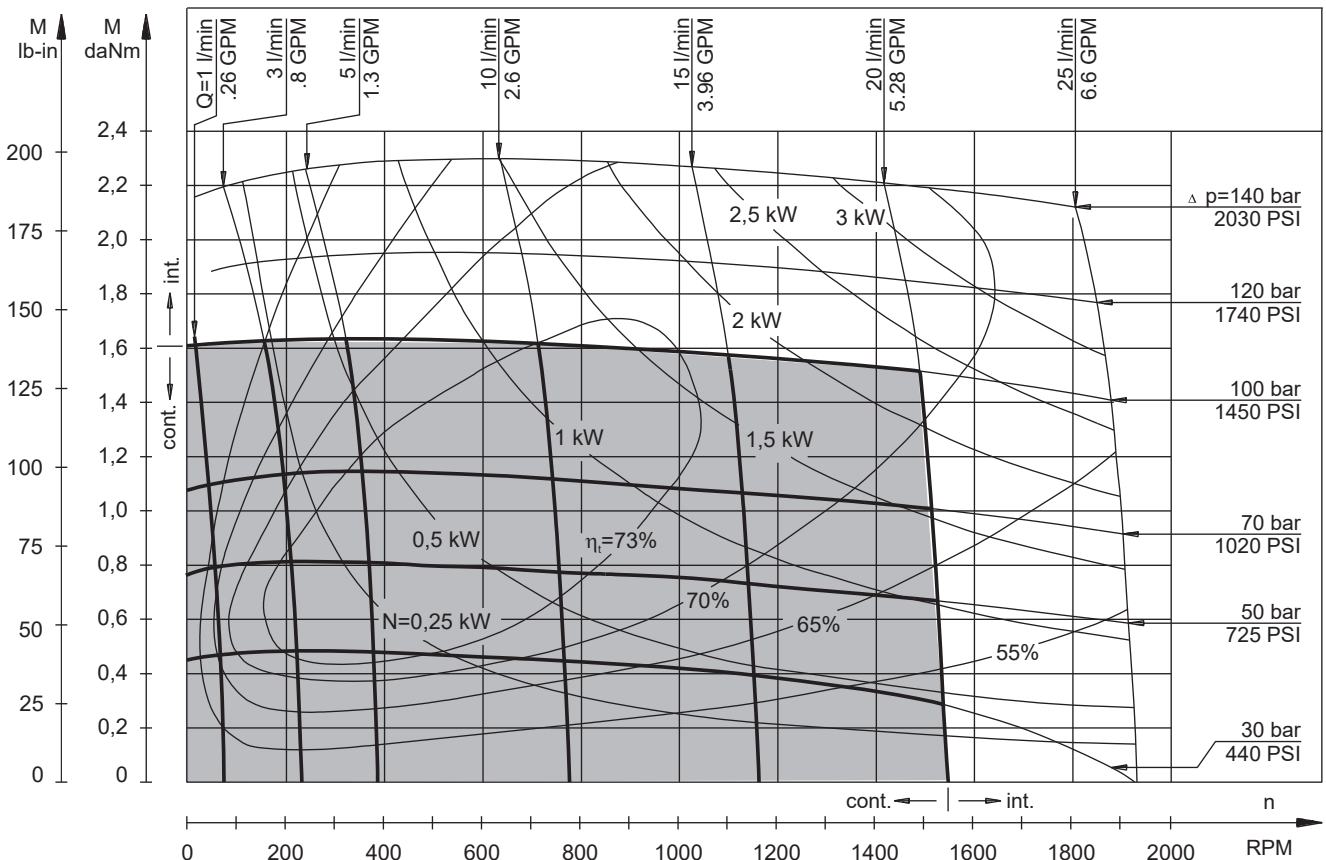

The function diagrams data is for average performance of randomly selected motors at back pressure 5÷10 bar [72.5÷145 PSI] and oil with viscosity of 32 mm²/s [150 SUS] at 50°C [122°F].

FUNCTION DIAGRAMS

MM 20

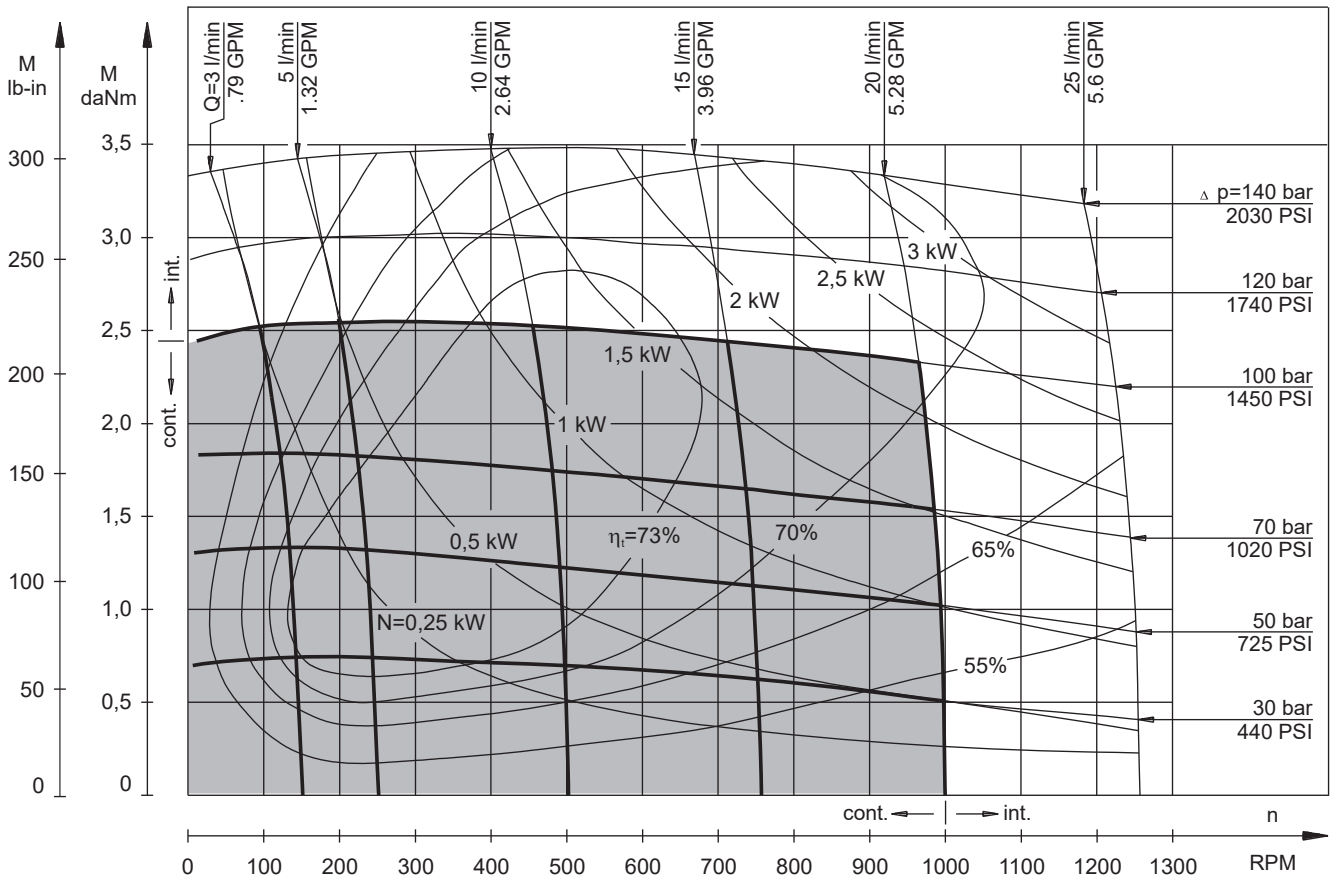

MM 32

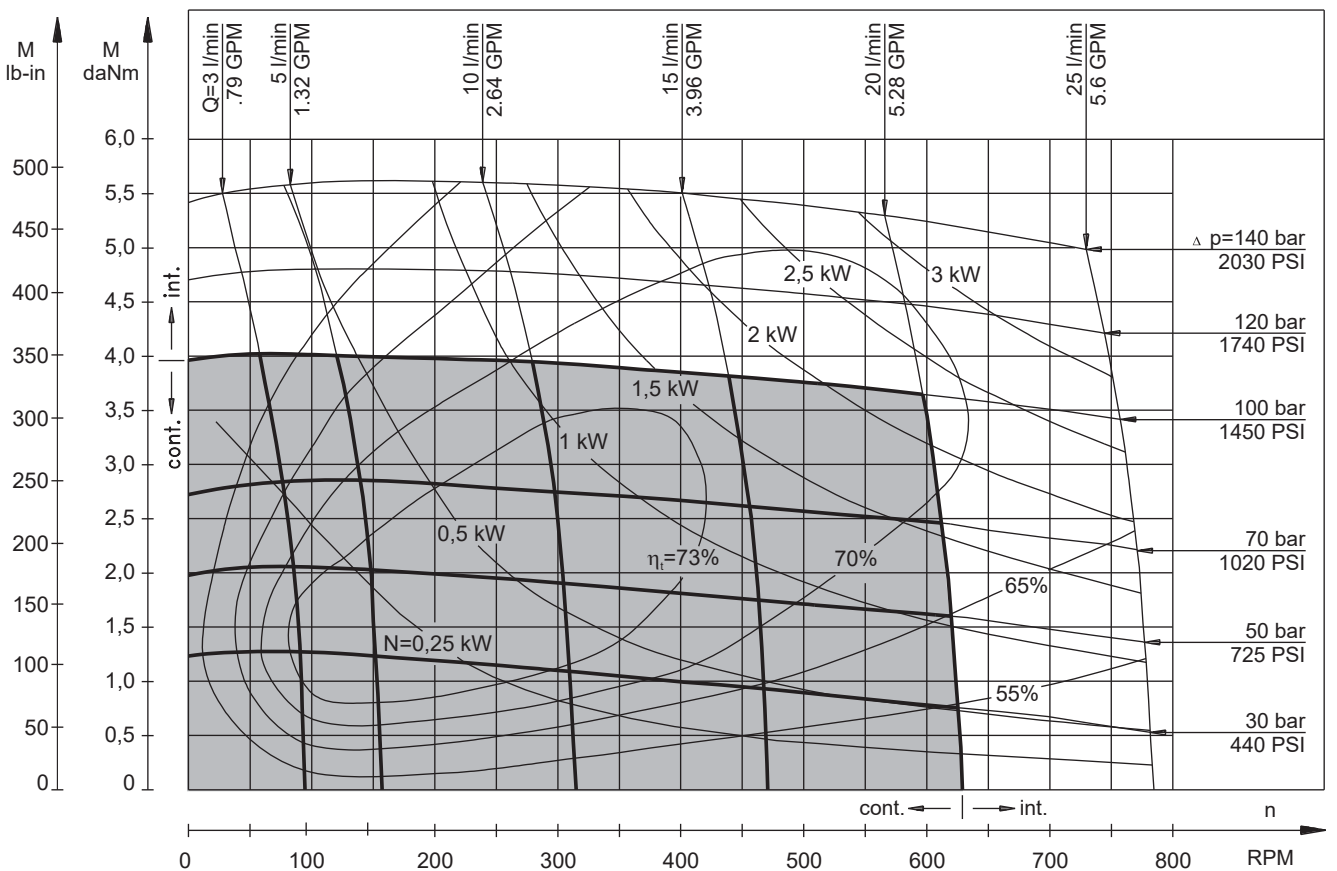

The function diagrams data is for average performance of randomly selected motors at back pressure 5÷10 bar [72.5÷145 PSI] and oil with viscosity of 32 mm²/s [150 SUS] at 50°C [122°F].

FUNCTION DIAGRAMS

MM 40

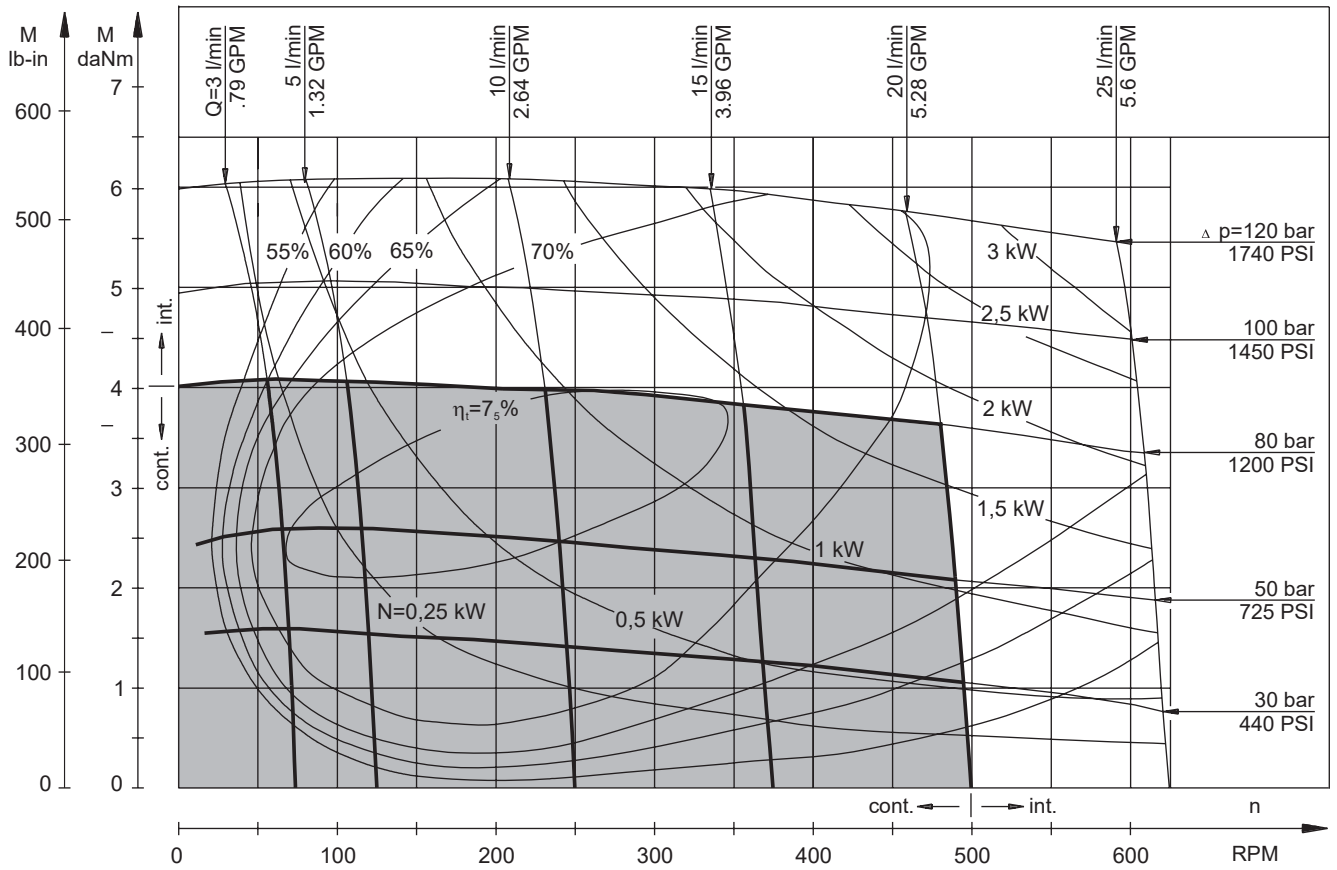

MM 50

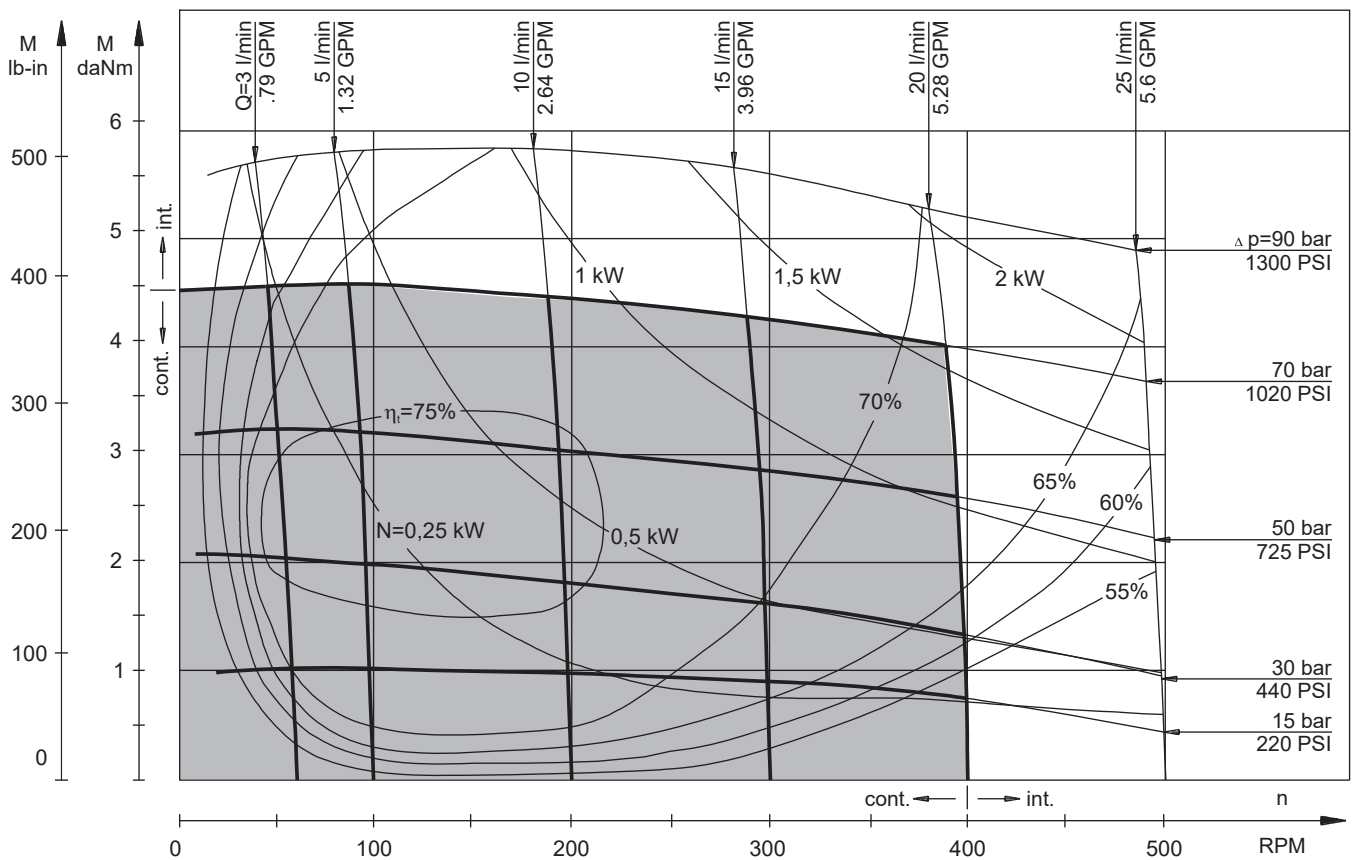

The function diagrams data is for average performance of randomly selected motors at back pressure 5÷10 bar [72.5÷145 PSI] and oil with viscosity of 32 mm²/s [150 SUS] at 50°C [122°F].

DIMENSIONS AND MOUNTING DATA
MM, MMS, MMP, MMD

Three Bolts Mount

SH Shaft C Shaft CK Shaft

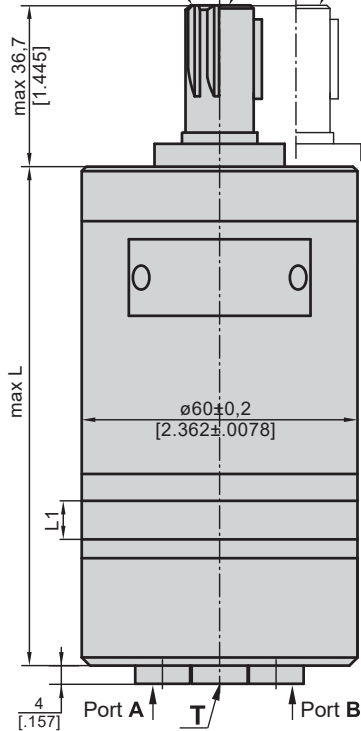

Rear Ports

Shaft Dim.
See Page 11

Flange Dim.
See Page 10

Port Dim.
See Page 10

F Oval Mount (2 Holes)

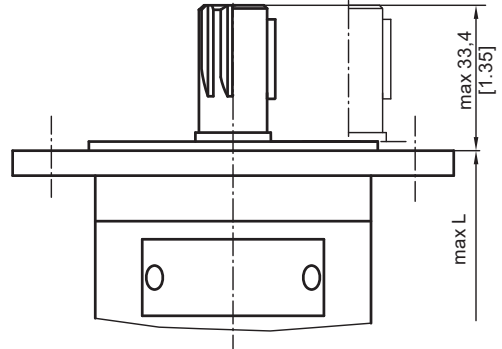

Standard Rotation

Viewed from Shaft End

Port A Pressurized - **CW**

Port B Pressurized - **CCW**

Reverse Rotation

Viewed from Shaft End

Port A Pressurized - **CCW**

Port B Pressurized - **CW**

S Side Ports

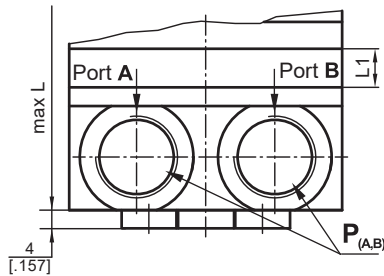

P Side Ports

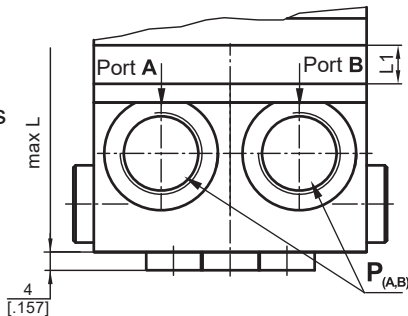

D Side Ports

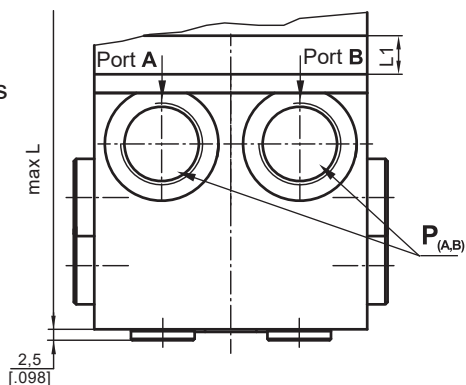

$P_{(A,B)}$: 2xG3/8 or 2xM18x1,5 - 12 mm [0.47 in] depth

T : G1/8 or M10x1 - 10 mm [0.39 in] depth

Type	L, mm [in.]	Type	L, mm [in.]	L_1 , mm [in.]
MM 8	104 [4.094]	MMS 8	105 [4.134]	3,5 [.138]
MM 12,5	106 [4.173]	MMS 12,5	107 [4.213]	5,5 [.217]
MM 20	109 [4.291]	MMS 20	110 [4.331]	8,5 [.335]
MM 32	114 [4.488]	MMS 32	115 [4.528]	13,5 [.531]
MM 40	117,5 [4.626]	MMS 40	118,5 [4.665]	17 [.669]
MM 50	121,5 [4.783]	MMS 50	122,5 [4.823]	21 [.827]

Type	L, mm [in.]	Type	L, mm [in.]	L_1 , mm [in.]
MMP 8	115 [4.528]	MMD 8	134 [5.276]	3,5 [.138]
MMP 12,5	117 [4.606]	MMD 12,5	136 [5.354]	5,5 [.217]
MMP 20	120 [4.724]	MMD 20	139 [5.472]	8,5 [.335]
MMP 32	125 [4.921]	MMD 32	144 [5.669]	13,5 [.531]
MMP 40	128,5 [5.039]	MMD 40	147,5 [5.807]	17 [.669]
MMP 50	132,5 [5.217]	MMD 50	151,5 [5.965]	21 [.827]

For "F" Flange +3,5 mm



MOUNTING

Three Bolts Mount

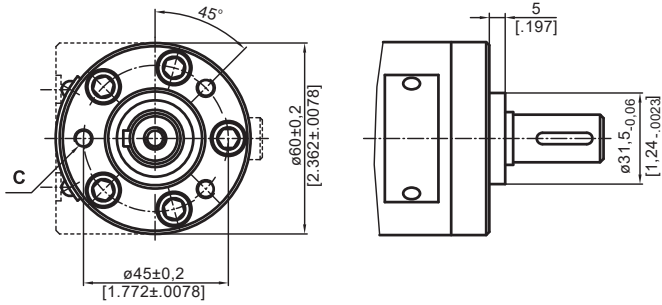

F Oval Mount (2 Holes)

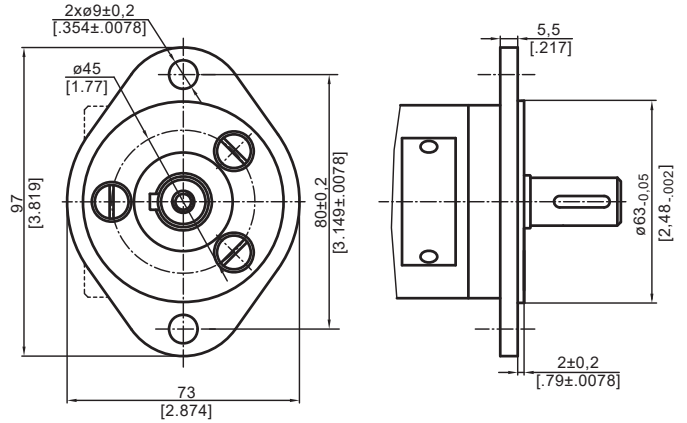

PORTS

Rear Ports

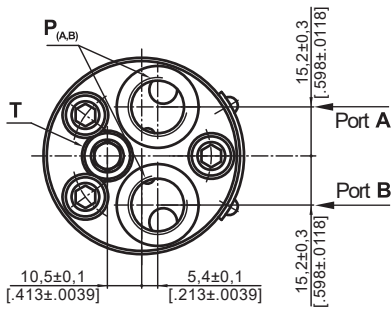

S Side Ports

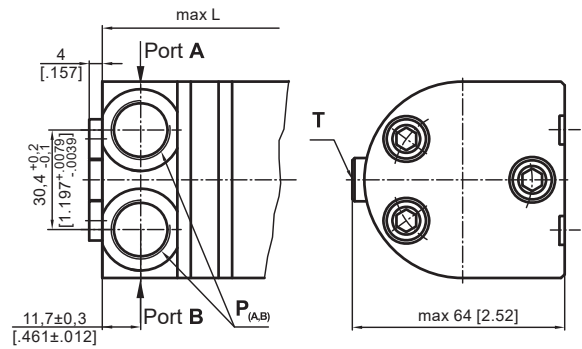

P Side Ports with Single Crossover Relief Valve

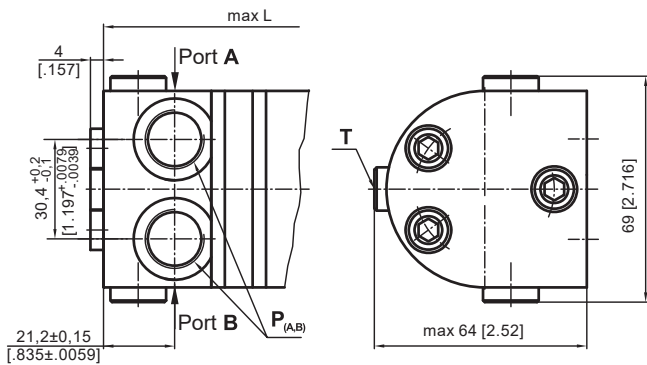

D Side Ports with Dual Crossover Relief Valve

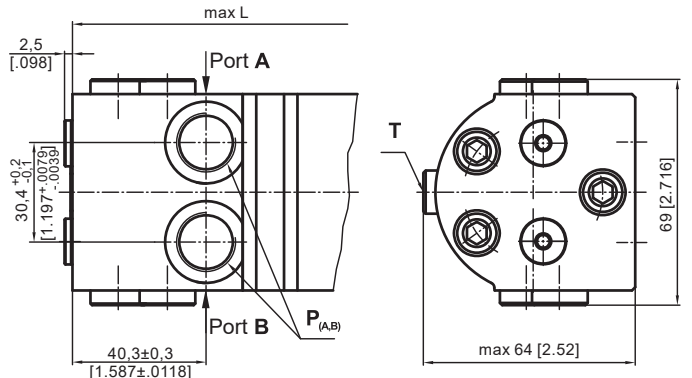

Standard Rotation
Viewed from Shaft End
Port A Pressurized - **CW**
Port B Pressurized - **CCW**

Reverse Rotation
Viewed from Shaft End
Port A Pressurized - **CCW**
Port B Pressurized - **CW**

C : 3xM6 - 12 mm [.47 in] depth
P_(A,B) : 2xG3/8 or 2xM18x1,5 - 12 mm [.47 in] depth
T : G1/8 or M10x1 - 10 mm [.39 in] depth

SHAFT EXTENSIONS

C - $\varnothing 16$ straight, Parallel key 5x5x16 DIN 6885
Max. Torque 3,9 daNm [345 lb-in]

CK - $\varnothing 14$ straight, Parallel key 5x5x16 DIN 6885
Max. Torque 3 daNm [265 lb-in]

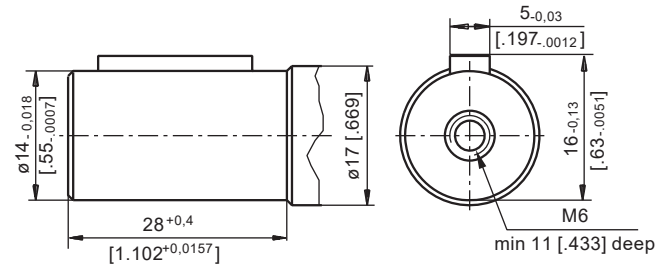
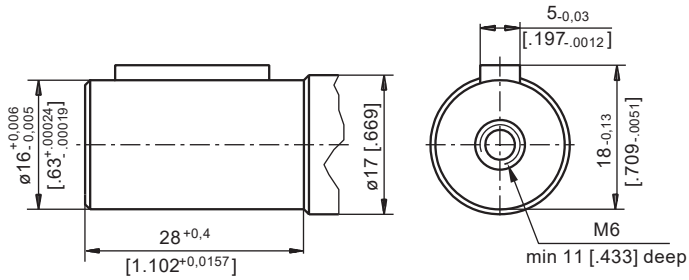

SH - $\varnothing 16,5$ Splined, B17x14 DIN 5482
Max. Torque 4,4 daNm [390 lb-in]

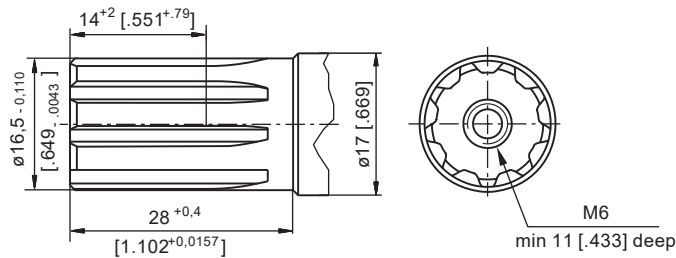

PERMISSIBLE SHAFT LOAD

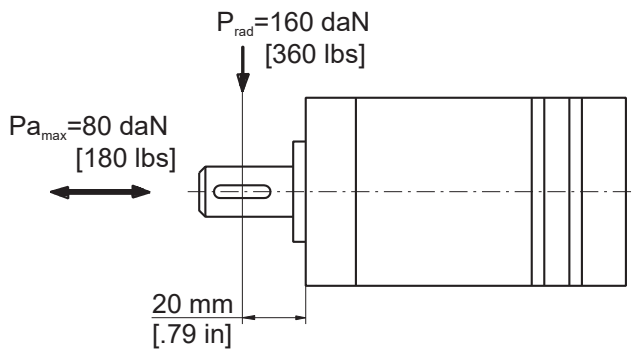

The permissible radial shaft load [Prad] is calculated from the distance [L] between the point of load application and the mounting surface:

$$P_{rad} = \frac{600}{n} \times \frac{13040}{61,5+L}, \text{ [daN]}$$

[L in mm; L ≤ 80 mm]

$$P_{rad} = \frac{600}{n} \times \frac{1155}{2,42 + L}, \text{ [lbs]}$$

[L in inch; L ≤ 3.15 in]

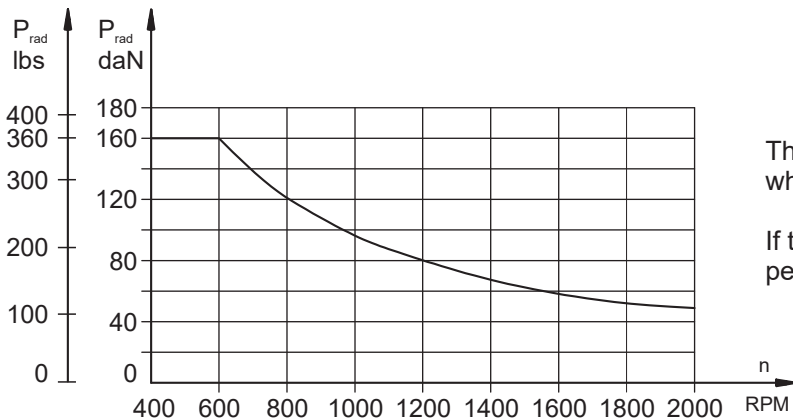

The drawing shows the permissible radial load when L=20 mm [.79 in].

If the calculated shaft load exceeds the permissible, a flexible coupling must be used.

ORDER CODE

	1	2	3	4	5	6	7	8	9
MM									

Pos.1 - Adjustment Option

- omit - without valve
- P** - Side ports with single crossover relief valve
- D** - Side ports with dual crossover relief valve

Pos.2 - Mounting Flange

- omit - Three bolts mount
- F** - Oval mount, two holes

Pos.3 - Port type (not valid for P and D version)

- omit - Rear ports
- S** - Side ports

Pos.4 - Displacement code

- | | |
|-------------|---|
| 8 | - 8,2 cm ³ /rev [.5 in ³ /rev] |
| 12.5 | - 12,9 cm ³ /rev [.79 in ³ /rev] |
| 20 | - 20,0 cm ³ /rev [1.22 in ³ /rev] |
| 32 | - 31,8 cm ³ /rev [1.93 in ³ /rev] |
| 40 | - 40,0 cm ³ /rev [2.44 in ³ /rev] |
| 50 | - 50,0 cm ³ /rev [3.05 in ³ /rev] |

Pos. 5 - Shaft Extensions*

- C** - ø16 straight, Parallel key A5x5x16 DIN6885
- VC** - ø16 straight, Parallel key A5x5x16 DIN6885 with corrosion resistant bushing
- CK** - ø14 straight, Parallel key 5x5x16 DIN6885
- SH** - ø16,5 splined, B17x14 DIN 5482

Pos. 6 - Ports

- omit - BSPP (ISO 228)
- M** - Metric (ISO 262)

Pos. 7 - Line to control ** (see page 4)

- /L** - B→A (left running)
- /R** - A→B (right running)

Pos. 8 - Valve Rated Pressure ***

- /50** - Δp=50 bar [725 PSI]
- /80** - Δp=80 bar [1160 PSI]
- /100** - Δp=100 bar [1450 PSI]
- /140** - Δp=140 bar [2030 PSI]

Pos. 9 - Special Features (see page 118)

Pos.10 - Design Series

- omit - Factory specified

NOTES:

- * The permissible output torque for shafts must not be exceeded!
- ** For **P** option useful only.
- *** For **P** and **D** option useful only.

! **MMP** and **MMD** are available with new crossover relief valves with improved characteristics. The new valves allow easier pressure setting in a wider range: from 50 bar [725 PSI] to 140 bar [2030 PSI]. For more information about MMP and MMD - series 2 please contact with "Bulmach Sp.z o.o".
The Valve pressure setting must be at flow rate of 2 lpm [.53 GPM].

The hydraulic motors are mangano - phosphatized as standard.

F - FLANGE (2 Holes)

Order No for Flange:48443 014 00

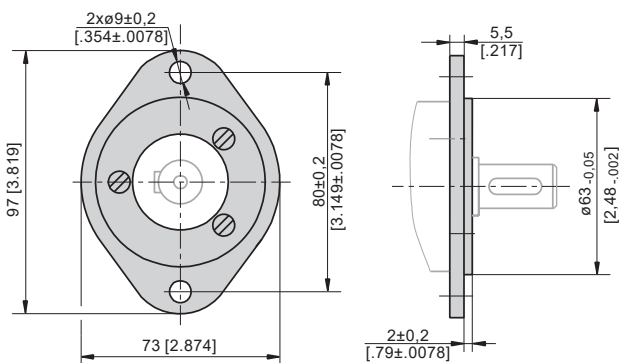

F Flange is mounted to the motor with 3 screws - M6x14. Tightening Torque: 5-6 Nm.